

**FALCON 2-60**

**VACUUM PACKAGING MACHINE**



**FEATURES**

- Standard with 2 seal bars: 2 x 450mm (front-back),
- Other seal bar configuration available for free: 2x 680mm (left-right)
- Standard double seal (two wires). Optional without extra costs: Cut-off/Wide seal
- Silicon holders easily removable for cleaning and maintenance purposes
- Pump capacity: 63 m<sup>3</sup>/h Busch vacuum pump
- Pump maintenance and cleaning program
- Machine cycle: 15-40 sec
- Standard Digital control with 10 program memory and Time control
- Comes with insert plates for a faster cycle and product adjustment
- Stainless steel frame
- Aluminium chamber and lid with sight glass

**OPTIONS**

- 1-2 Cut-off seal
- Bi-active seal
- Soft Air
- Sensor control, Advanced Control System (ACS)
- Liquid control
- Gas flush

**ACCESSORIES**

- Zebra ZD410 thermal label printer (only in combination with ACS)
- Inclined insert plate (for packing liquids)
- Service kit for standard maintenance

**DESCRIPTION**

The robust Falcon 2-60 vacuum packaging machine with stainless steel frame is standard equipped with a Busch vacuum pump, an aluminium lid and vacuum chamber and 2 seal bars. This double chamber complies with CE standards.



Henkelman offers standard 3 year warranty

**SEAL BAR CONFIGURATION**

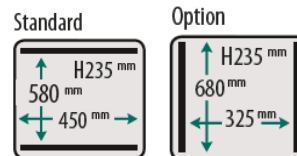

# VACUUM PACKAGING MACHINE FALCON 2-60 – SPECS

VACUUM PACKAGING MACHINE FALCON 2-60 – SPEC SHEET

## DIMENSIONS

In mm

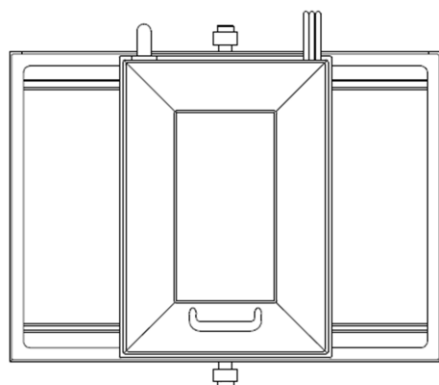

OUTER DIMENSIONS

Falcon 2-60

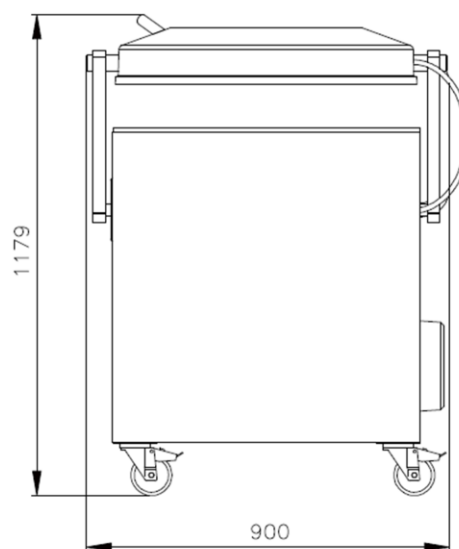
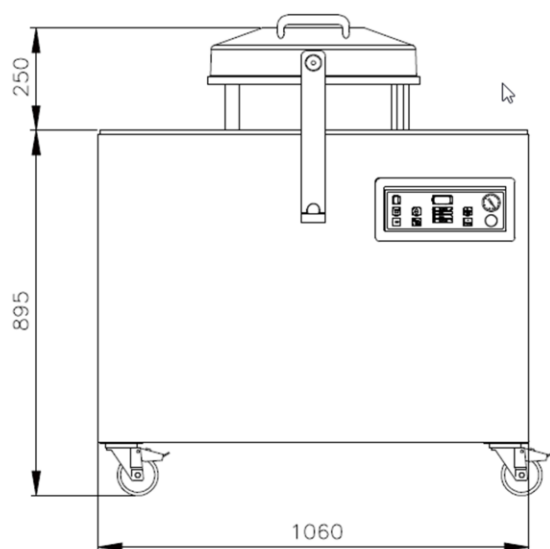

Model	Dimensions (mm)		Voltage* (Hz)	Pump capacity (m <sup>3</sup> /h)	Power (kW)	Weight (kg)
	Chamber (usable space) L x W x H	Machine L x W x H				
Falcon 2-60	580 x 450 x 235	900 x 1060 x 1179	400V-3-50	63	2,4 - 3,5	236

\* Other voltages available



HENKELMAN BV  
Titaniumlaan 10  
5221 CK 's-Hertogenbosch  
The Netherlands

**Sales support**  
P +31 73 621 36 71  
E [info@henkelman.com](mailto:info@henkelman.com)  
**Service/technical support**  
P +31 73 621 36 71  
E [service@henkelman.com](mailto:service@henkelman.com)